



**MOTOROLA**  
intelligence everywhere™



**NOVA**  
COMMUNICATIONS

**MOTOROLA**  
Authorized Dealer & Service Center

**MOTOSTAR**  
1-800-333-3333

**MOTOROLA**  
Authorized Channel Partner  
Fixed Wireless Broadband Solutions

**Nova Communications**

Canada's Premier Supplier  
of Wireless Communications  
We Put Wireless to Work!  
1-877-721-7070

[www.novacomcommunications.com](http://www.novacomcommunications.com)



Professional Series  
Two-Way Radio Service & Installation Manual

**CDM-Series**  
Control Station

# Product Software License Agreement

THIS LICENSE AGREEMENT BETWEEN YOU, THE USER, AND MOTOROLA, APPLIES TO THE SOFTWARE EMBEDDED IN OR DELIVERED WITH THE ACCOMPANYING MOTOROLA PRODUCT (“SOFTWARE”), AND IS APPLICABLE UNLESS A SIGNED LICENSE AGREEMENT COVERING ITS SUBJECT MATTER HAS BEEN EXECUTED BETWEEN YOU AND MOTOROLA. BY USING THE PRODUCT, YOU ACKNOWLEDGE THAT THIS AGREEMENT HAS BEEN READ AND UNDERSTOOD AND THAT YOU AGREE TO BE BOUND BY ITS TERMS AND CONDITIONS. IF YOU DO NOT AGREE, YOU ARE NOT LICENSED TO USE THE PRODUCT, AND IF YOU ARE THE PURCHASER OF THE PRODUCT, YOU SHOULD IMMEDIATELY RETURN THE PRODUCT IN ITS ENTIRETY TO ITS PLACE OF PURCHASE FOR A REFUND.

Motorola grants to You a non-exclusive license to use the SOFTWARE in the manner described in the documentation associated with the product. Motorola retains ownership of the SOFTWARE including all patent, copyrights, and other intellectual property rights. You may transfer this license to use the SOFTWARE as long as the transferee agrees to be bound by the terms of this Agreement.

You agree not to reverse engineer or create derivative works of the SOFTWARE; not to transmit the SOFTWARE electronically; not to modify, configure, or use the SOFTWARE in any manner not authorized by MOTOROLA; and, except as an integral part of the product, not to rent, lease, or convey the SOFTWARE.

MOTOROLA SHALL NOT BE LIABLE FOR INCIDENTAL OR CONSEQUENTIAL DAMAGES ARISING FROM THE USE OF THIS SOFTWARE.

With respect to the U.S. Government, if acquired under FAR policy (52.227-19), the SOFTWARE is provided with Restricted Rights, and if acquired under DFARS policy (227.7202), then the SOFTWARE is provided only with the commercial rights of this Agreement.

This license is effective until terminated. It will terminate immediately and automatically if You fail to comply with any term of this Agreement.

You agree that this is the complete and exclusive statement of the agreement between You and Motorola and that any modification of these terms shall be made only by mutual agreement and evidenced by written amendment signed by both parties. This Agreement shall be governed and interpreted by the laws of the State of Illinois, United States of America.

## Computer Software Copyrights

This manual may not be reproduced, in whole or in part, in any form whatsoever, without the express written permission of Motorola, Inc.

The Motorola products described in this manual contain one or more computer programs. These computer programs are protected by copyright law and international treaties. Unauthorized reproduction or distribution of these programs, or any part thereof, may result in severe civil and criminal penalties, and will be prosecuted to the maximum extent possible under the law. U.S. and international patents pending.

**This product is covered by one or more issued U.S. Patents. Other Patent applications pending.**

---

## Foreword

Scope of Manual . . . . .	iii
How to Use This Manual . . . . .	iii
Other Documentation . . . . .	iii
Technical Support and Service . . . . .	iii
Regulatory Requirements . . . . .	iii
Product Safety and RF Exposure Compliance . . . . .	iii
Electrostatic Discharge – Sensitive Parts . . . . .	iii
Accessories . . . . .	iv
Service Aids . . . . .	v
Test Equipment . . . . .	v

## Section 1

### Introduction to the CDM Control Station

Overview . . . . .	1
CDM Control Station . . . . .	1
Mobile Radio Compatibility . . . . .	1
Physical Description . . . . .	1
CDM Control Station Housing . . . . .	1
CDM Control Station Fan Assembly . . . . .	1
CDM Control Station Power Supply . . . . .	1
CDM Control Station Interface Circuit Boards . . . . .	2
Cables . . . . .	2
Preventive Maintenance . . . . .	3
Visual Inspection . . . . .	3
Periodic Cleaning . . . . .	3

## Section 2

### CDM Control Station Operation

Overview . . . . .	1
General Description . . . . .	1
Performance . . . . .	1
General Specifications . . . . .	1
Control Functions and Indicators . . . . .	1
Transmit . . . . .	1
Monitor . . . . .	1
Intercom . . . . .	2
Supervisory . . . . .	2
Speaker Volume . . . . .	2
Audio Sources and Level Adjustments . . . . .	2
Microphone Sources . . . . .	2
Speaker . . . . .	2
Accessory RX . . . . .	2
Audio States . . . . .	2
Transmit Audio . . . . .	2
Intercom Audio . . . . .	2
RX Audio . . . . .	2
Operator Instructions . . . . .	2

Receiving Calls . . . . .	2
Initiating Calls . . . . .	2

### Section 3 CDM Control Station Installation

Overview . . . . .	1
General considerations . . . . .	1
Interface Module settings . . . . .	1
Switch Settings . . . . .	1
Switch 1, Intercom/Parallel TX Audio Enable . . . . .	1
Switch 2, Intercom Audio From the Control Station to Accessory TX Port . . . . .	1
Switch 3, Intercom Audio From the Control Station to Accessory RX Port . . . . .	1
Switch 4, Mute Accessory RX Audio During Intercom . . . . .	1
Switch 5, Intercom Audio From Local Mic . . . . .	1
Switch 6, Intercom Audio From Desk Mic . . . . .	1
Switch 7, Intercom Audio From Headset Mic . . . . .	1
Switch 8, Accessory Transmit Mutes Local Speaker . . . . .	1
Default Settings . . . . .	1
Jumper Settings . . . . .	1
Adjusting Audio Levels . . . . .	1
Additional Considerations . . . . .	2
Radio Control Head Speaker . . . . .	2
Radio Programming Parameters . . . . .	2
Desk Microphone . . . . .	2
Basic Disassembly/Assembly . . . . .	2
Disassembling the CDM Control Station Housing . . . . .	2
Removing the Housing Cover . . . . .	2
Disassembling the Inner Chassis . . . . .	2
Assembling the CDM Control Station Housing . . . . .	3
Installing the Radio . . . . .	3
Installing the Ground Stud . . . . .	3
Connecting the Power Supply . . . . .	3
Attaching the AC Power Cord . . . . .	4
Replacing the Cover . . . . .	4
Field Installation . . . . .	4

### Section 4 CDM Control Station Theory of Operation

Audio Paths . . . . .	1
Transmit Audio . . . . .	1
Intercom/Parallel Transmit Audio . . . . .	1
Receiver Audio . . . . .	1
Digital functions . . . . .	1
Mic Selection . . . . .	1
PTT . . . . .	1
Monitor . . . . .	1

### Section 5 CDM Control Station Troubleshooting

CDM Control Station Interface Module (CSIM), Audio Section . . . . .	1
CDM Control Station Interface Module (CSIM), Digital Section . . . . .	2
CDM Control Station I/O, CSAP and CSKP . . . . .	3
CDM Control Station Circuit Board Details . . . . .	4

## Scope of Manual

This manual is intended for use by experienced technicians familiar with similar types of equipment. It contains all service information required for the equipment described and is current as of the printing date. Changes which occur after the printing date are incorporated by service manual revisions. These revisions are added to the manuals as the engineering changes are incorporated into the equipment.

## How to Use This Manual

This manual contains introductory material such as model charts and accessories, as well as sections that deal with specific service aspects of the CDM Control Station. Refer to the Table of Contents for a general overview of the manual, or to the "Overview" paragraph in each section for a specific overview of the information in that section.

## Other Documentation

Table 1 lists other documentation you may need to setup and configure the Control Station.

**Table 1. Other Documentations**

Information	Location
CDM-Series Operation (North America)	CDM750 User Guide (6881091C54) CDM1250 User Guide (6881091C55) CDM1550 User Guide (6881091C56)
CDM-Series Programming (North America)	CDM-Series CPS HVN9025
CDM-Series Service (North America)	Basic Service Manual (6881091C62) Detailed Service Manual (6881091C63)

## Technical Support and Service

For Technical Support, please call:

Motorola Inc.  
(800) 927-2744

If it is necessary to return a unit for repair or replacement, the call-taker will issue a Return Material Authorization (RMA) number. Include the RMA number in the package with the defective unit.

For information on warranty service, returns or repairs, contact:

Motorola Inc.  
Radio Support Center  
2204 Galvin Dr.  
Elgin, IL 60123  
(800) 227-6772

To order parts, contact:

Motorola Inc.  
2200 Galvin Drive  
Elgin, IL 60123  
(800) 422-4210

## Regulatory Requirements

In the United States, the FCC regulates licensing of RF frequencies. The terms of the FCC radio license for a particular operation will determine the frequencies, output power, and antenna height(s) for a given situation. The applicable "Part" of the FCC Rules and Regulations must be consulted before a CDM Control Station is activated. In countries other than the United States, contact the local government for licensing rules.

### NOTE

In the United States of America, the CDM-Series radios may not legally be used as the transmit radio in a UHF (450 to 512 MHz) repeater or base station application with 12.5 kHz channel spacing. The  $\pm 2.5$ -ppm frequency stability capability of the radio does not meet the requirements of part 90 of the Rules and Regulations of the Federal Communications Commission (FCC). In other countries, check local frequency stability requirements before placing a CDM-Series radio based repeater or base station in operation.

## Product Safety and RF Exposure Compliance



Before using this product, read the operating instructions for safe usage contained in the Product Safety and RF Exposure booklet enclosed with your radio.

### ATTENTION!

**This radio is restricted to occupational use only to satisfy FCC RF energy exposure requirements.** Before using this product, read the RF energy awareness information and operating instructions in the Product Safety and RF Exposure booklet enclosed with your radio (Motorola Publication part number 68P81095C99) to ensure compliance with RF energy exposure limits.

For a list of Motorola-approved antennas, batteries, and other accessories, visit the following web site which lists approved accessories: <http://www.motorola.com/cgiss/index.shtml>.

## Electrostatic Discharge – Sensitive Parts

This product contains CMOS and other circuit components which may be damaged by electrostatic discharge. Proper precaution must be taken when handling circuit modules. As a minimum, grounded wrist straps should be used at all times when the control station cover is removed and in the handling of circuit modules.

See section 11.9 of the Motorola R56-Standards and Guidelines for Communications Sites for more detailed information.

## Accessories

Motorola offers several accessories to increase communications efficiency. Many of the accessories available are listed below, but for a complete list, consult your Motorola dealer.

### Desksets

L3211	MC1000 Basic Local Deskset
L3212	MC1000 DC Remote Control Deskset with 4 Freq.
L3213	MC1000 Tone Remote Control with 4 Freq.
L3167	Tone Remote Adapter; 2 Freq. with 4-Wire Audio
L3151	DC Remote Adapter; 16 Freq. with 4-Wire Audio

### Microphones

HMN3000	Desk Microphone, black
HLN9573_R	Shorting Plug Kit for Microphone Jack

### Headsets

CDN6281A	PTT Base
CDN6297A	Single ear
CDN6290A	Noise Canceling single ear
CDN6295A	Over the ear
CDN6288A	Noise Canceling over the ear
CDN6285A	Over the ear w/ rear ear support for greater stability
CDN6292A	Noise canceling over the ear w/ rear ear support for greater stability
CDN6287A	Dual Ear
CDN6294A	Noise canceling dual ear

### Antennas

RDD4527	150-158 MHz, VHF 3 dB Gain
RDE4556	450-470 MHz, UHF 3.8 dB Gain

### General Accessories

RRX4025	Type "N" Connector Coaxial In-line Arrestor
RRX4032	Tower Mount Hardware w/In-line Arrestor
ST788	1/2" Jacketed Helix Coaxial Ground Clamps
HLN9457	16-Pin Accessory Connector Kit
3080517U10	Mini-UHF to N-Bulkhead RF Adapter Cable
3080137S02	Radio Interface Cable

### Manuals/Software

6881091C54	CDM750 Mobile Radio User Guide
6881091C55	CDM1250 Mobile Radio User Guide
6881091C56	CDM1550 Mobile Radio User Guide
6881091C62	CDM-Series Mobile Radio Basic Service Manual
6881091C63	CDM-Series Mobile Radio Detailed Service Manual
HVN9025	CDM-Series CPS Programming

## Service Aids

The following table lists service aids recommended for working on the CDM Control Station.

Motorola Part No.	Description	Application
HLN9214	Radio Interface Box	Enables communication between the radio and the computer's serial communications adapter.
HSN9412	RIB Power supply	Used to supply power to the RIB.
HKN9216	Computer Interface cable	Connects the computer's serial communications adapter to the RIB.
HKN9217	Program Test Cable	RIB to Radio Cable
HVN9025	CDM-Series CPS	Software on 3-1/2 in. diskettes.

## Test Equipment

The following table lists test equipment required to service the CDM Control Station.

Motorola Model No.	Description	Characteristics	Application
R2200, R2400, or R2001	Service Monitor	This monitor will substitute for items with an asterisk *	Frequency/deviation meter and signal generator for wide-range troubleshooting and alignment
*R1049	Digital Multimeter		Two meters recommended for ac/dc voltage and current measurements
*S1100	Audio Oscillator	67 to 200 Hz tones	Used with service monitor for injection of PL tones
*S1053, *SKN6009, *SKN6001	AC Voltmeter, Power Cable for meter, Test leads for meter	1mV to 300V, 10-Megohm input impedance	Audio voltage measurements
R1053	Dual-trace Oscilloscope	20 MHz bandwidth, 5mV/cm - 20V/cm	Waveform measurements
*S1350, *ST1215 (VHF) *ST1223 (UHF) *T1013	Wattmeter, Plug-in Elements (VHF & UHF), RF Dummy Load	50 Ohm, $\pm 5\%$ accuracy, 100 Watts, maximum 0-1000 MHz, 300 Watts	Transmitter power output measurements
S1339	RF Millivolt Meter	100 $\mu$ V to 3V RF, 10 kHz to 1.2 GHz	RF level measurements
*R1013	SINAD Meter		Receiver sensitivity
S1347 or S1348 (prog)	DC Power Supply	0-20 Vdc, 0-5 Amps	Bench supply for 12.5 Vdc







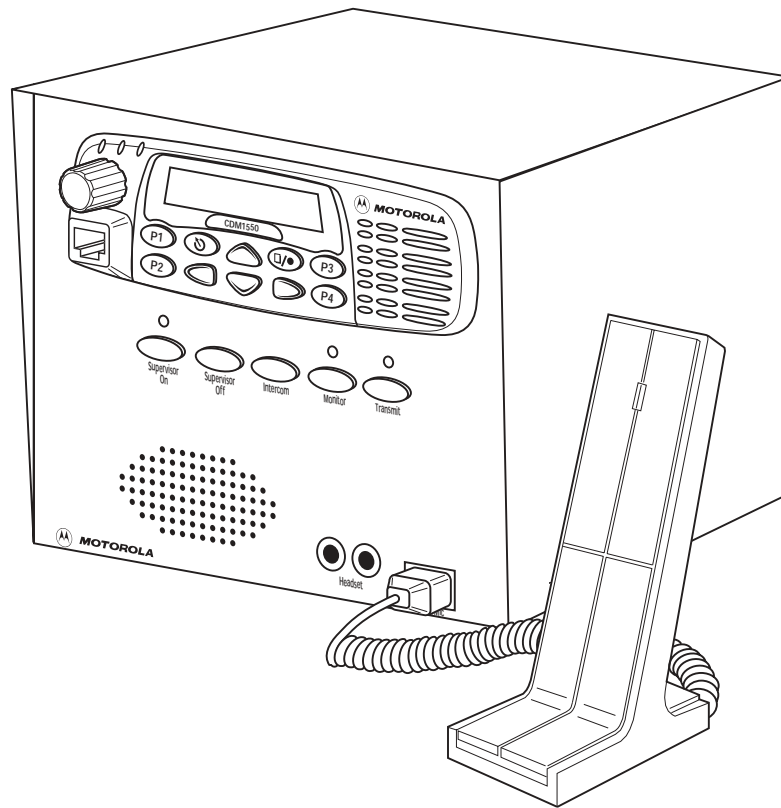

*Figure 1-1. CDM Control Station*

### **CDM Control Station Interface Circuit Boards**

The Control Station contains three circuit boards and an internal speaker that together provide the enhanced control functions. The Control Station Interface Module (CSIM) is the main board located beneath the radio inside the inner chassis and mounted using card guides. This module contains all logic, control, and interface circuitry. The Control Station Audio Panel (CSAP) is located on the housing base just behind the front panel. It provides the physical external audio accessory connectors. The Control Station Key Panel (CSKP) assembly is located on the front panel and provides the buttons and LED indicators necessary for local dispatch operation. A speaker is mounted to the front panel of the cabinet which allows for monitoring of radio receive audio, accessory intercom, and accessory transmit audio.

### **Cables**

The coaxial cables that connect the radio to the Control Station back panel are fabricated from RG58A/U (the cable used with most of the mobile antenna kits). Do not use RG58A/U as the coaxial cable that connects the antenna connector of the Control Station to the antenna. The rather small size of the RG58A/U can introduce excessive losses in the system that will decrease the effective range of the Control Station.

Substitute RG400/U for short lengths and RG214/U or 1/2-inch "hardline" for the longer lengths. If the "hardline" is used, connect the antenna connector of the Control Station to the end of the "hardline" with a flexible jumper cable. This will avoid undue stress on the connectors of the cables and the Control Station.

Table 1-1 can be used to determine which feedline to choose for a given frequency band and line length to maintain 1.5 dB (approximately 30%) or less power loss. Table 1-2 is a list of Motorola part numbers for the various connectors and cables.

*Table 1-1. Maximum Feedline Length in Feet (Meters)*

<b>Band</b>	<b>RG400/U</b>	<b>RG214/U</b>	<b>Hardline</b>
Low (50 MHz)	55 (17)	100 (30)	300 (90)
VHF (150 MHz)	25 (7.5)	50 (15)	150 (45)
UHF (450 MHz)	15 (4.5)	25 (7.5)	90 (27)
800 MHz	10 (3)	20 (6)	70 (21)

*Table 1-2. Part Numbers for Connectors/Cables*

<b>Part</b>	<b>Motorola Part Number</b>
mini-UHF male connector	2884606M01
UHF male connector	2884579F04

**Table 1-2. Part Numbers for Connectors/Cables (Cont.)**

Part	Motorola Part Number
type-N male connector	2884476G01
type-N 1/2" hardline male	TDN6677
type-N 1/2" hardline female	TDN6678
RG58A/U coaxial cable	3000475378
RG400/U coaxial cable	3084173E01
RG214/U coaxial cable	3015068A17
1/2" hardline cable	3080329A22
8 ft. jumper cable	TDN8406A*
type-N f-f adapter	5882764A01*

\*Use of the type-N f-f adapter may be required to connect the jumper cable to the main feedline.

## Preventive Maintenance

Preventative maintenance of the Control Station consists of visual inspections and periodic cleaning.

### Visual Inspection

Check that external surfaces of the equipment are clean, that connecting cables are not damaged, and that connections are

firm. A detailed inspection of the interior electronic circuitry is not needed or desired.

### Periodic Cleaning

Periodically clean smudges and grime from the exterior housing. Use a soft, non-abrasive cloth moistened in a mild soap and water solution. Rinse the surface using a second cloth moistened in clean water, and clean any dirt or debris from the fan grill.



# Section 2

## CDM Control Station Operation

### Overview

This section contains information about the control functions, audio sources, audio states, programmable features and operator instructions for the CDM Control Station.

### General Description

The Control Station is an integrated base station package designed for fixed locations. It serves as a local dispatch point providing enhanced local control and supports common audio accessories such as a desk microphone or headset.

### Performance

The Control Station was designed for the Professional Series mobile radios. It is intended for fixed locations where protection from the elements (snow, rain, etc.) can be provided. The station is relatively light and portable.

The fan is controlled by a thermal switch connected to the power supply. This switching minimizes noise in office environments while providing maximum cooling at elevated ambient temperatures or during heavy transmit duty cycles. The station is defined as intermittent transmit duty cycles, but it may have surprisingly lower power slump when keyed for long periods in an office shop environment.

### General Specifications

Dimensions	8.3" W x 13.3" L x 7.5" H (21.1cm W x 33.8cm L x 19cm H) approx.
Weight	11.5 lbs (5.2 kg) approx.
Power Input	10.5 to 16 V dc
Input Current	Less than 1 Amp, full audio
Speaker Audio Output	1.5 W min. into 16 ohms at reference input
Transmit Audio Output	80mV RMS Nominal with nominal Mic. Inputs
Accessory Audio Output	1 W min. into 8 ohms at reference input
Headset Audio Output	160 mV at reference input
Audio Distortion	Less than 3% THD

Hum and Noise	Greater than 45 dB below rated outputs
Audio Frequency Response	+/- 3 dB from 300 Hz to 3000 Hz at 1 KHz ref.
User Adjustments	Speaker audio level (on Radio)
	Accessory RX audio output
	Headset RX audio level
	Intercom audio level
Ambient Temperature	0° C to 50° C
Humidity	90%, Non-condensing

*Specifications Subject to change without notice.*

### Control Functions and Indicators

#### Transmit

The radio transmitter is keyed whenever PTT is activated from one of the following sources: front panel Transmit button, desk microphone PTT, headset PTT, or PTT from an accessory device. The Transmit LED, located above the Transmit button on the front panel, is illuminated whenever the transmitter is keyed in this manner.

#### Monitor

Before transmitting, the selected channel should be checked for co-channel activity by using the Monitor function. RX squelch is disabled when Monitor is asserted from any of the following sources: front panel Monitor button, desk microphone Monitor button, or Monitor from an accessory device. The Monitor LED, located above the Monitor button on the front panel, is illuminated whenever RX squelch is disabled in this manner.

**NOTE**

The Control Station is configured at the factory to operate with a desk microphone. If a desk microphone is not to be used, shorting jumper JU5 on the interface module allows the Monitor indication LED to operate in conjunction with a different audio source; otherwise, the LED is ON continuously.

**Intercom**

The intercom function allows the operator to communicate with desk set users in the system without transmission over the radio channel. When the front panel user presses the Intercom button, microphone audio from the selected source (headset, local microphone, or desk microphone) is routed based on switch programming.

**Supervisory**

The Supervisory function provides the ability to override parallel dispatch points. The Supervisory function is latched On or Off via the corresponding front panel buttons. When latched On, the Supervisor ON LED is illuminated and accessory PTT is inhibited.

**Speaker Volume**

The internal speaker volume is controlled by the radio's volume knob located on the radio control head.

**Audio Sources and Level Adjustments****Microphone Sources**

The Control Station provides paths for transmit audio and intercom audio. Transmit audio is defined to be microphone audio from the base station user or a connected accessory (local desk set, phone patch, etc.) which is broadcast on the radio channel. Intercom audio refers to local conversations between the accessory and base station front panel users.

Local sources of transmit/intercom audio are: a headset, desk microphone, or the front panel microphone. Microphone selection is accomplished via programming switches.

**Speaker**

Radio RX audio and Intercom/Transmit audio from the accessory (parallel audio) are summed at the speaker. Thus, the base station user can hear both channel audio and accessory (desk set) audio. Accessory audio at the speaker can be disabled by switch programming.

Volume of radio RX audio is adjustable using the control knob on the mobile's control head. Volume of the accessory intercom/transmit audio is adjustable via a pot located on the back panel of the inner chassis.

Headset volume of radio RX audio is adjustable via a pot located on the back panel of the inner chassis.

**NOTE**

Accessory (parallel) audio is routed only to the speaker, not the headset.

**Accessory RX**

Accessory RX audio level is adjustable via a pot located on back panel of the Control Station inner chassis.

**Audio States****Transmit Audio**

Microphone audio from the accessory is summed with microphone audio from the local microphone source (headset, local microphone, or desk microphone) and fed to the mobile microphone audio input.

**Intercom Audio**

When the front panel user presses the Intercom button, microphone audio from the selected source (headset, local microphone, or desk microphone) is routed based on switch programming. If switch 3 is on, audio is routed to the accessory RX audio port. This is necessary to allow intercom for desk sets with no ability to monitor transmit audio.

If switch 3 is off, audio is routed to the accessory microphone port. This is intended for desk sets that are capable of monitoring transmit audio.

**RX Audio**

Radio RX audio is routed to the speaker and the accessory RX audio port. When the base station user is pressing Intercom to talk with the accessory user, the RX audio path to the accessory can be disabled, depending on switch programming.

**Operator Instructions****Receiving Calls**

The Control Station is normally in the receive mode upon power-up and remains in this mode until a user transmits via the Control Station or parallel accessory device. The Control Station contains an internal speaker through which Receive Audio is heard. The speaker volume is controlled by the radio volume knob. Optionally, a headset can also be used for receiving calls. In this case, one may wish to turn the radio volume down to a minimal level.

**Initiating Calls**

To initiate a call, first depress the Monitor button and verify that the radio channel is clear. Press and hold the Transmit

button while speaking into the microphone. Release the button to listen. Transmission is accomplished by using one of the following microphones:

- **Desk Microphone**

The Control Station is configured by default to use a desk microphone. DIP switch 6 should be in the ON position.

- **Headset**

The Control Station can be configured to operate with a headset. DIP switch 7 should be in the ON position.

- **Internal Microphone**

The Control Station comes equipped with an internal microphone intended for use in low noise environments. The local microphone is active anytime the front panel Transmit button is pressed. DIP switch 5 should be in the ON position.







## Additional Considerations

requirements of each installation. These levels are set with trim pots located on the back panel of the inner chassis.

- **POT1 (IC/MON)**  
This potentiometer allows adjustment of the Intercom/Parallel audio level to the internal speaker.
- **POT2 (ACC RX)**  
This potentiometer allows the Accessory RX audio level to be set.
- **POT3 (HEADSET)**  
This potentiometer provides audio level adjustment for Radio RX to the Headset.

## Additional Considerations

### Radio Control Head Speaker

Since the Control Station comes equipped with an internal speaker, it is recommended that the radio speaker (located in control head) be disabled. This is accomplished by removing the front panel of the control head and unplugging the speaker lead wires.

### Radio Programming Parameters

The Control Station requires that several radio parameters be configured to allow proper Control Station operation.

*Table 3-1. Jumper Settings*

Jumper	Function	In	Out (default)
JU1	Headset mic audio output level	Gain added	Nominal Gain
JU2	Local mic audio output level	Gain added	Nominal Gain
JU3	Desk mic audio output level	Gain added	Nominal Gain
JU4	Accessory mic audio output level	Gain added	Nominal Gain
JU5	Desk mic monitor logic	Desk mic not installed	Desk mic installed

Before beginning installation, remove all items from the packing container and check them against the items referenced in one of the parts lists on page 3-7. This assures that you have received all items necessary to assembly the Control Station. Immediately report any missing or damaged items to Motorola Product Services.

The following steps explain how to disassemble the Control Station housing and how to reassemble it while installing the radio and necessary cables.

### Disassembling the CDM Control Station Housing

The following steps cover the disassembly of the Control Station housing. Refer to Figure 3-3 and Figure 3-4 on pages 3-7 and 3-8 for identification of each part and its corresponding reference number.

#### NOTE

- Accessory Configuration/RX Audio Type must be set for Filtered Audio.
- Accessory Pins/Pin #3 must be set for External Mic PTT (Input).

### Desk Microphone

JU1 of the Desk Microphone (HMN3000) must be installed to allow proper base station intercom operation. The jumpers keeps the microphone circuit active at all times, thus allowing proper base station intercom function. Instructions for installing this jumper can be found in the HMN3000 Installation Guide, 6880903Z37.

## Basic Disassembly/Assembly

#### NOTE

Unless specifically instructed otherwise, DO NOT discard any hardware removed during disassembly.

In order to conserve space in the packing box, the Control Station housing is shipped completely assembled with the fan assembly, top cover, power supply, and control circuitry installed. To install the radio and configure the unit, the Control Station may have to be completely disassembled. With the Control Station disassembled, you can begin to install the radio and configure the Interface Module before reassembling the housing.

### Removing the Housing Cover

1. Place the Control Station on a flat surface.
2. Observe proper procedures for handling ESD sensitive devices.
3. Remove the six (6) TT3.5mm, pan head Taptite screws, located on the sides of the housing using a Torx T15 driver.
4. From the front, lift the top cover up until it clears the base, turning it on its side and placing it on the surface at a 90 degree angle from the base.

### Disassembling the Inner Chassis

Most installations will not require access to the Control Station Interface Module (CSIM) located inside the inner chas-

sis. However, if jumper settings must be changed, disassembly of the inner chassis will be required.

1. Remove the screw which secures the CSIM board to the back panel of the inner chassis.
2. Remove the four (4) TT3.5mm, pan head Taptite screws that secure the inner chassis to the base.
3. Loosen the two (2) M5mm, pan head machine screws that secure the power supply to the inner chassis.
4. Carefully slide the inner chassis towards the back of the base until the pcb interface cables are accessible from the front.
5. Unplug the ribbon cable from the Control Station Audio Panel (CSAP), being careful not to break the connector guide posts.
6. Unplug the ribbon cable from the Control Station Key Panel (CSKP), being careful not to break the connector guide posts.
7. Pull the CSIM board forward and disconnect the speaker lead connector.
8. Remove the CSIM board from the inner chassis and configure as necessary.

### Assembling the CDM Control Station Housing

The following steps enable you to reassemble the Control Station. Refer to Figure 3-3 and Figure 3-4 on pages 3-7 and 3-8 for identification of each part and its corresponding reference number.

If the inner chassis was disassembled, reassemble at this time by reversing the disassembly steps.

### Installing the Radio

1. Slide the radio through the front panel of the housing into the inner chassis and secure with two (2) M5mm, machine screws. The front panel radio slot will be a tight fit as the control head is positioned in the opening. The inner chassis uses a slotted hole that allows the installer to adjust depth of the radio in the chassis.
2. If you are installing the optional Internal RF Cable, order part number 3080517U10.
3. Remove the nut and lockwasher from the cable.
4. Insert the type-N female bulkhead connector into the "Antenna" D-hole located on the enclosure back panel, beneath the fan. The threaded portion of the connector will stick out the back of the cabinet.

5. Replace the lockwasher and nut onto the connector. Tighten to 2.26 N-m (20 in.-lbs.) torque.
6. Connect the mini-UHF connector of the cable to the antenna connector of the radio.
7. Remove the accessory dust cover from the radio.
8. Connect one end of the radio interface cable to the accessory connector of the radio.
9. Connect the other end of the radio interface cable to the "Radio" connector of the CSIM, located on the inner chassis back panel. Pay particular attention to the connector orientation in relation to the locking tab.

### Installing the Ground Stud

#### NOTE

The Ground Stud is factory-installed in the Control Station.

### Connecting the Power Supply

1. Locate the power supply cable with the 2-prong "Ford" connector and connect to the DC power connector of the radio.
2. Locate the thermal switch mounting clip supplied with the Control Station. Slip the mounting clip onto the thermal switch, from the power supply. Refer to Figure 3-1.
3. Place the thermal switch and mounting clip, in-between the long fins (5 an 6 on the antenna connector side) of the radio's heatsink. Refer to Figure 3-1.
4. Carefully push the thermal switch mounting clip securely onto fin 6.

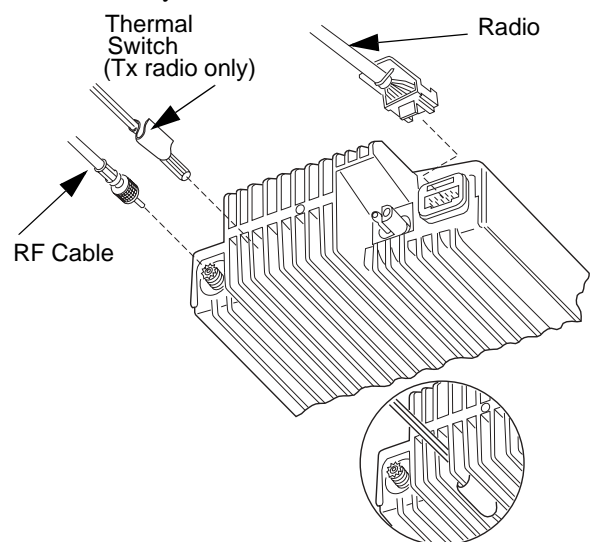
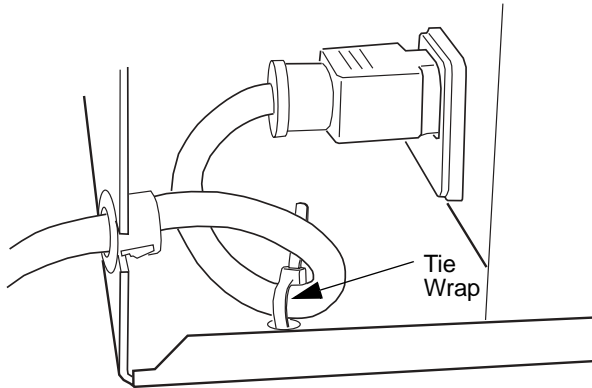

Figure 3-1. Professional Series Transmit Radio, Rear View

### Attaching the AC Power Cord

1. Locate the AC power cord and a nylon tie wrap.
2. Plug the female connector of the AC power cord into the IEC receptacle located on the back of the power supply.



*Figure 3-2. Service Loop*

3. Use the tie wrap to anchor the "service loop" to the chassis through the two holes in the bottom of chassis as shown in Figure 3-2. Trim off the excess tie wrap.

### Replacing the Cover

1. Rotate the cover and stand on its end such that the rear panel (with fan) is on the surface with the inside facing the rear of the enclosure base.
2. Lower the cover onto the enclosure base by tilting the top (as it stands) toward the front panel.
3. Align the mounting holes and ensure all cables are inside of the unit.
4. Using a T15 Torx driver, secure the cover to the base with the six (6) TT 3.5mm, pan head Taptite screws removed in Step 3, "Removing the Housing Cover".

### Field Installation

To operate the Control Station, the AC line cord, antenna feed line, ground cable, and optional accessory cable must exit from the rear of the unit.

In addition, you must connect all of the necessary cables and accessories as follows:

1. Attach a ground wire from an absolute earth ground to the 1/4" threaded ground stud on the left of the station housing.
2. Connect lightning arrestors.
3. Connect the antenna lead to the antenna connector on the back panel of the Control Station housing.

---

### IMPORTANT

Before connecting the AC line cord into an AC mains outlet, ensure that the "115/230" VAC switch on the power supply is in the appropriate position. The switch is accessible from the bottom of the Control Station housing.

---

4. Plug the AC line cord into an AC mains outlet.

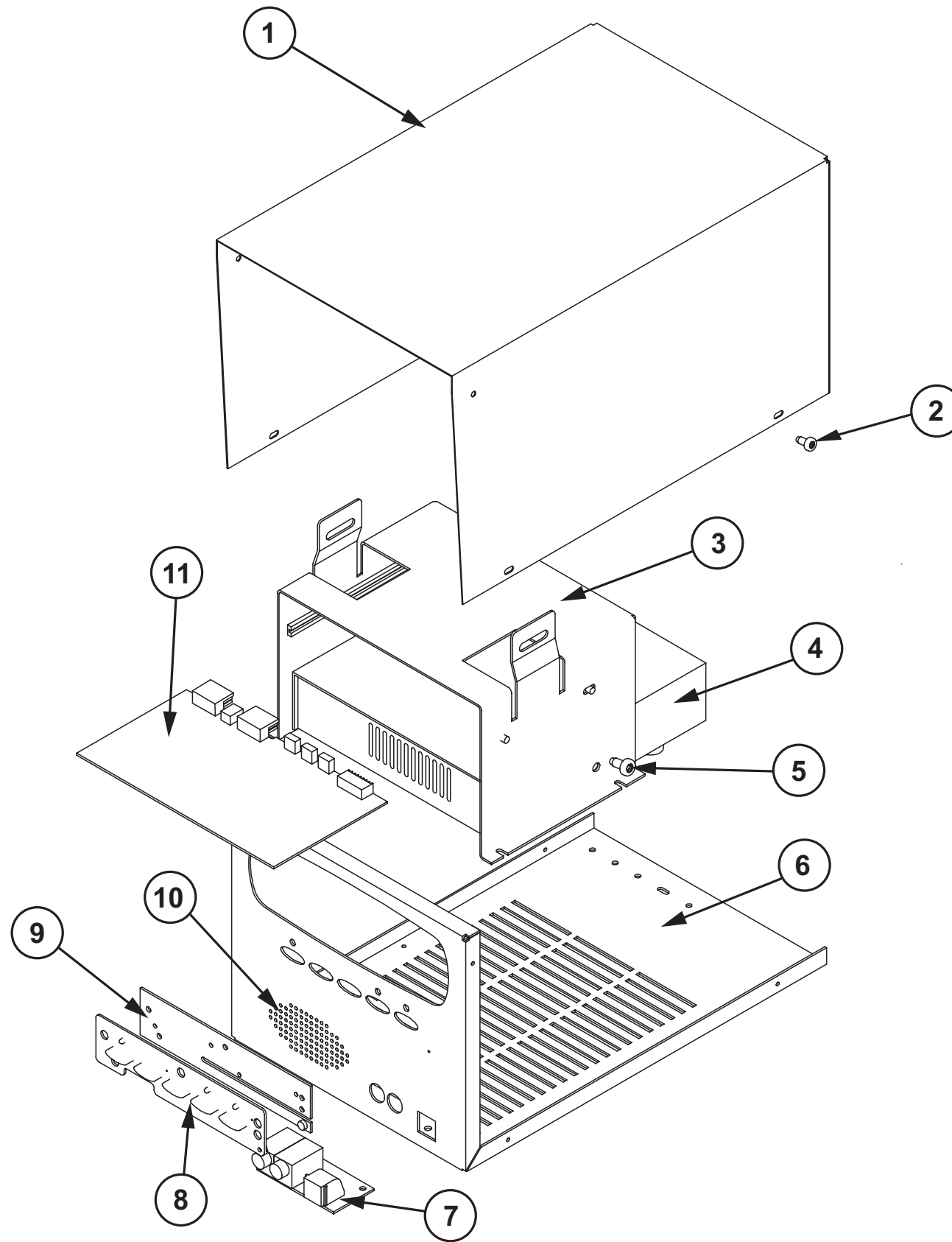

## Parts List

CDM Control Station  
RLN5403 Replacement Parts

PL-201030-O

REFERENCE SYMBOL	MOTOROLA PART NO.	DESCRIPTION	QTY.
1	15-80384N52	COVER, Housing, CDM Control Station	1
2	03-12016A52	SCREW, TT3.5 x 0.6 x 6mm, Pan, Star, Black Taprite	10
3	15-80384N55	INNER CHASSIS, Housing, CDM Control Station	1
4	HPN9033	POWER SUPPLY with AC Line Cord	1
5	03-10907B08	SCREW, M5 x 0.8 x 8mm, Pan, Star, Black, Machine	2
6	15-80384N52	BASE, Housing, CDM Control Station	1
7	0180305K02	ASSEMBLY, PCB, Audio Panel, CDM Control Station	1
8	75-80384N51	KEYPAD, CDM Control Station	1
9	0180305K03	ASSEMBLY, PCB, Key Panel, CDM Control Station	1
10	7580384N51	ASSEMBLY, Speaker	1
11	0180305K04	ASSEMBLY, PCB, Interface Module, CDM Control Station	1
12	01-80557U01	FAN with Connector	1
13	13-83852R01	GRILLE, Fan	1
14	3080517U10	RF CABLE, Internal Mini-UHF Male to "N" Bulkhead Female, 15 inches	1
15	42-85866M01	CLIP, Thermal Switch	1
16	30-80137S02	CABLE, Internal Radio Interface	1
17	30-82933N08	CORD, AC Line, IEC to U.S. 115 V (p/o HPN9033)	1
<b>non-referenced items</b>			
see note		TIE WRAP, approx. 4" (not shown)	3
see note		SCREW, Hex Head, 1/4-20 x 1", Zinc	1
see note		NUT, Hex, 1/4-20, Zinc	2
see note		WASHER, 1/4 External Tooth, Zinc	2
see note		SCREW, 4-40 x 0.25 LG, Pan, Phillips, Zinc	1
see note		NUT, Hex 4-40, Plain, Zinc	7

**Note:** Non-referenced items cannot be ordered through Motorola, but can be purchased at any local hardware store.

Figure 3-3. CDM Control Station

# Parts List

CDM Control Station  
RLN5403 Replacement Parts

PL-201030-O

REFERENCE SYMBOL	MOTOROLA PART NO.	DESCRIPTION	QTY.
1	15-80384N52	COVER, Housing, CDM Control Station	1
2	03-12016A52	SCREW, TT3.5 x 0.6 x 6mm, Pan, Star, Black Taptite	10
3	15-80384N55	INNER CHASSIS, Housing, CDM Control Station	1
4	HPN9033	POWER SUPPLY with AC Line Cord	1
5	03-10907B08	SCREW, M5 x 0.8 x 8mm, Pan, Star, Black, Machine	2
6	15-80384N52	BASE, Housing, CDM Control Station	1
7	0180305K02	ASSEMBLY, PCB, Audio Panel, CDM Control Station	1
8	75-80384N51	KEYPAD, CDM Control Station	1
9	0180305K03	ASSEMBLY, PCB, Key Panel, CDM Control Station	1
10	7580384N51	ASSEMBLY, Speaker	1
11	0180305K04	ASSEMBLY, PCB, Interface Module, CDM Control Station	1
12	01-80557U01	FAN with Connector	1
13	13-83852R01	GRILLE, Fan	1
14	3080517U10	RF CABLE, Internal Mini-UHF Male to "N" Bulkhead Female, 15 inches	1
15	42-85866M01	CLIP, Thermal Switch	1
16	30-80137S02	CABLE, Internal Radio Interface	1
17	30-82933N08	CORD, AC Line, IEC to U.S. 115 V (p/o HPN9033)	1
<b>non-referenced items</b>			
see note		TIE WRAP, approx. 4" (not shown)	3
see note		SCREW, Hex Head, 1/4-20 x 1", Zinc	1
see note		NUT, Hex, 1/4-20, Zinc	2
see note		WASHER, 1/4 External Tooth, Zinc	2
see note		SCREW, 4-40 x 0.25 LG, Pan, Phillips, Zinc	1
see note		NUT, Hex 4-40, Plain, Zinc	7

**Note:** Non-referenced items cannot be ordered through Motorola, but can be purchased at any local hardware store.

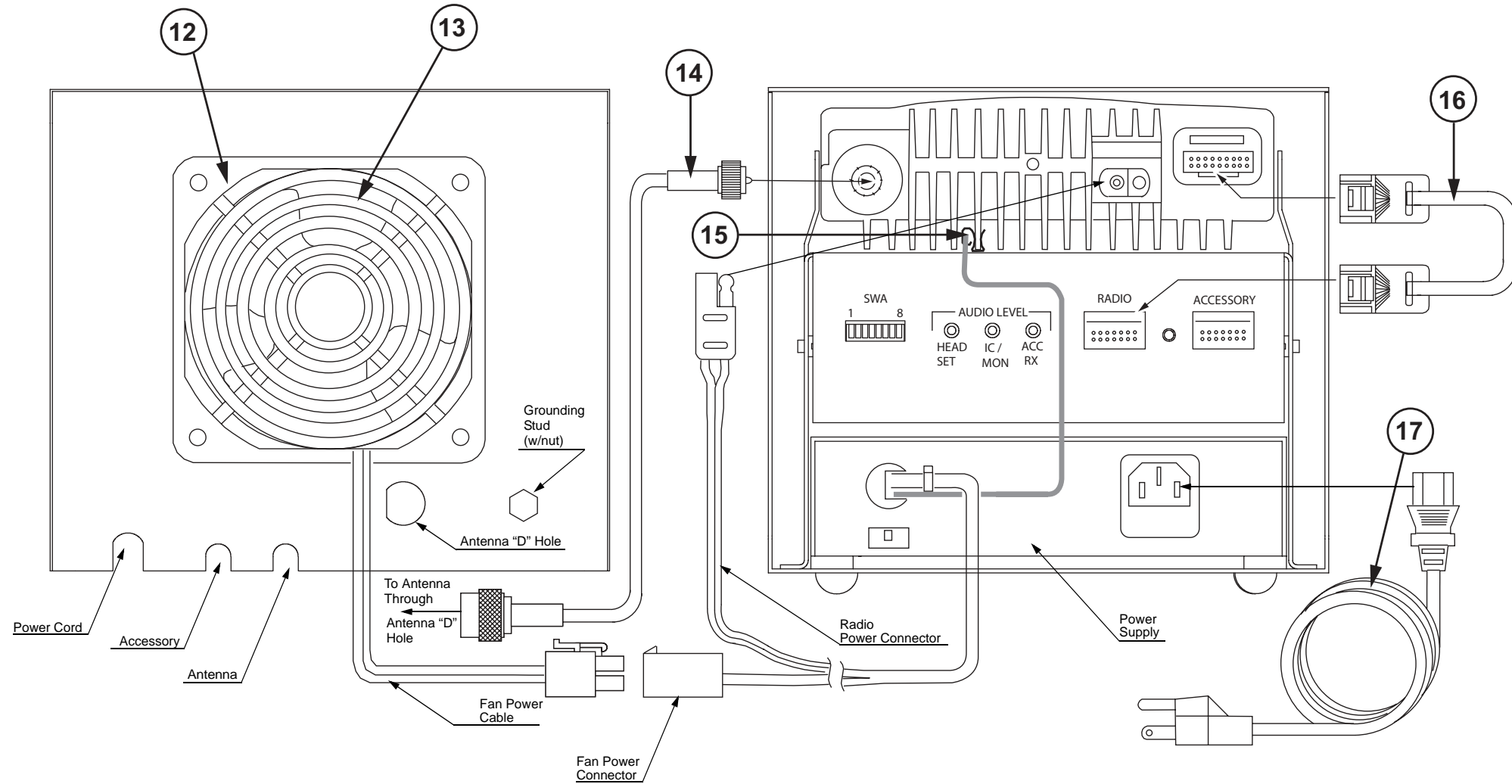

Figure 3-4. CDM Control Station Interconnect Cabling Diagram



Digital functions



# Section 5

## CDM Control Station Troubleshooting

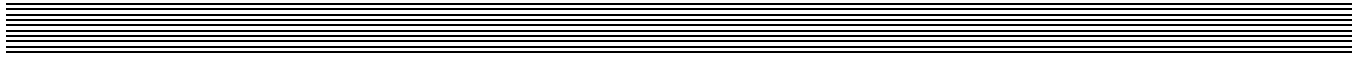

*Table 5-1. Troubleshooting for the CDM Control Station*

Problem	Possible Solution(s)	Reference
The control station will not key the mobile.  No Transmit LED.	Check the cabling to the radio and the control station.  Ensure proper radio programming. Verify Fuse is OK.	“Assembling the CDM Control Station Housing” beginning on page 3-3. “Radio Programming Parameters” on page 3-2.
The Monitor LED is always “ON”.	The control station by default expects a desk mic. If another audio accessory is to be used, reprogram switch settings accordingly.	“Interface Module settings” on pages 3-1 and page 3-12.
Desk Mic does not provide Intercom audio.	The desk mic must have a jumper installed to allow proper operation.	“Desk Microphone” on page 3-2.
Receive Audio is distorted.	Ensure that Accessory Configuration/RX Audio on the radio is set for Filtered Audio.	“Radio Programming Parameters” on page 3-2.
Unable to communicate with field radios.	Ensure radios are programmed with the correct TPL/DPL code.  Verify correct I/O programming of the accessory connector of the control station radio.  Verify correct programming of field radios.  Verify control station cabling.	CDM-Series Programming Software.
Unable to Intercom with Desksets.	Check for proper wiring of deskset and control station.	Deskset installation guide; Control Station I/O schematic.



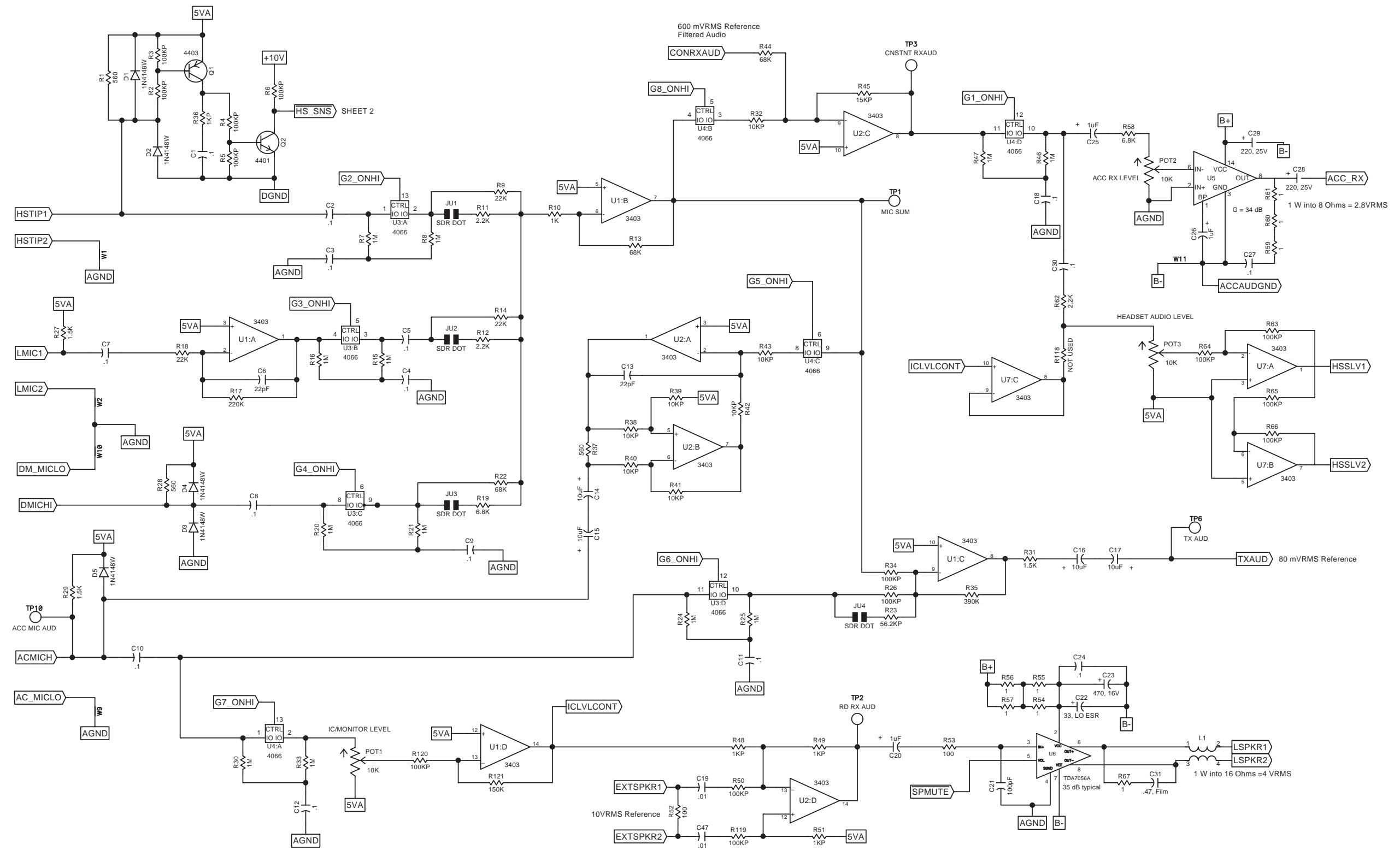

CDM Control Station Interface Module (CSIM), Audio Section



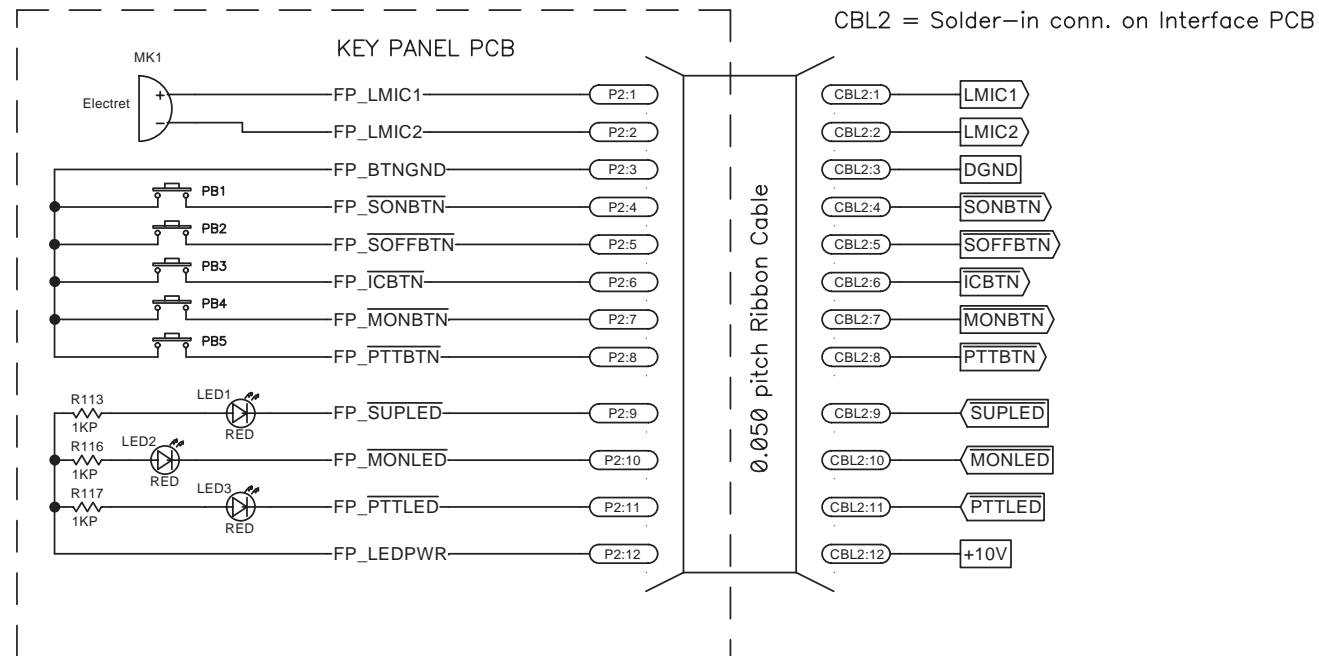

FRONT PNL SPEAKER

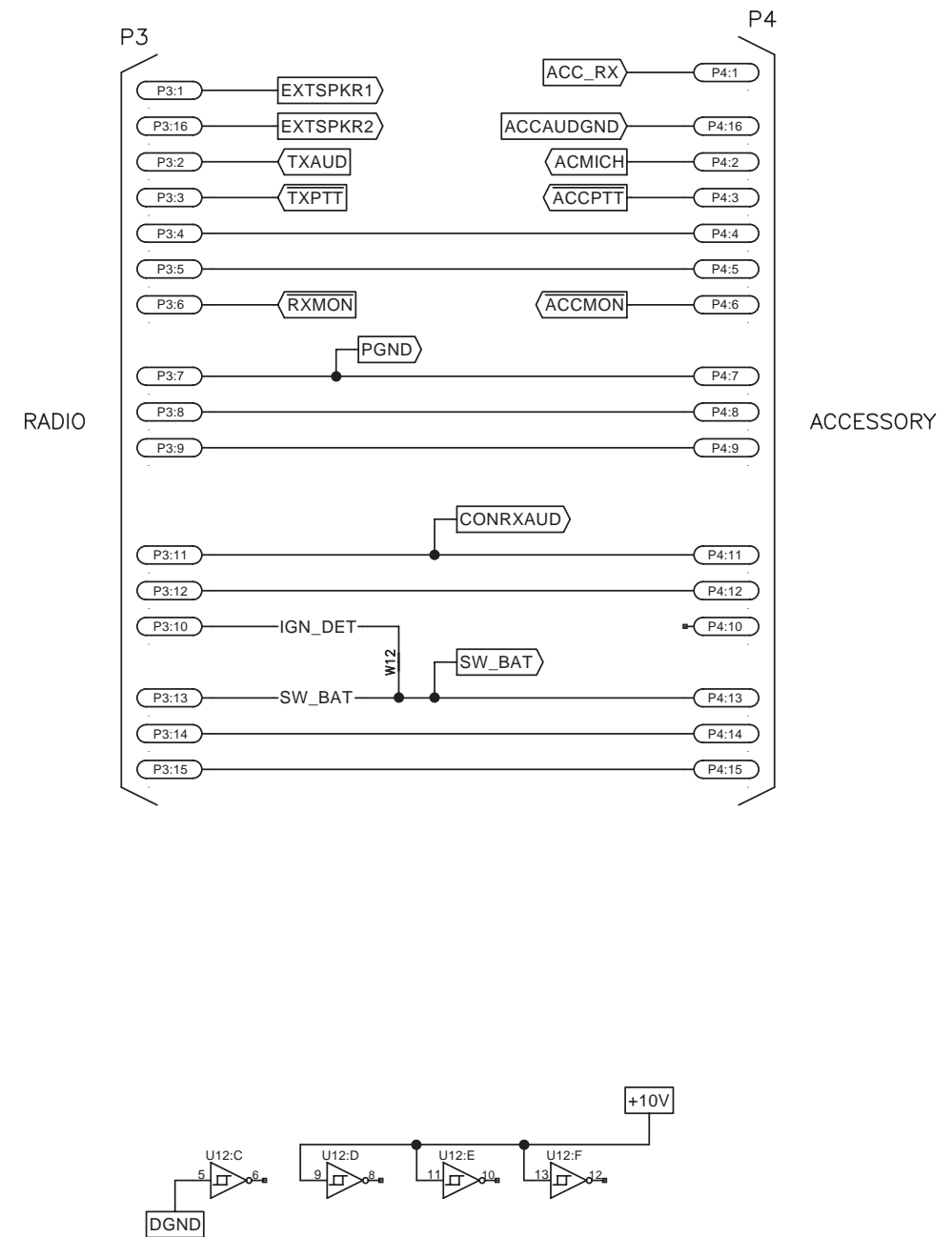
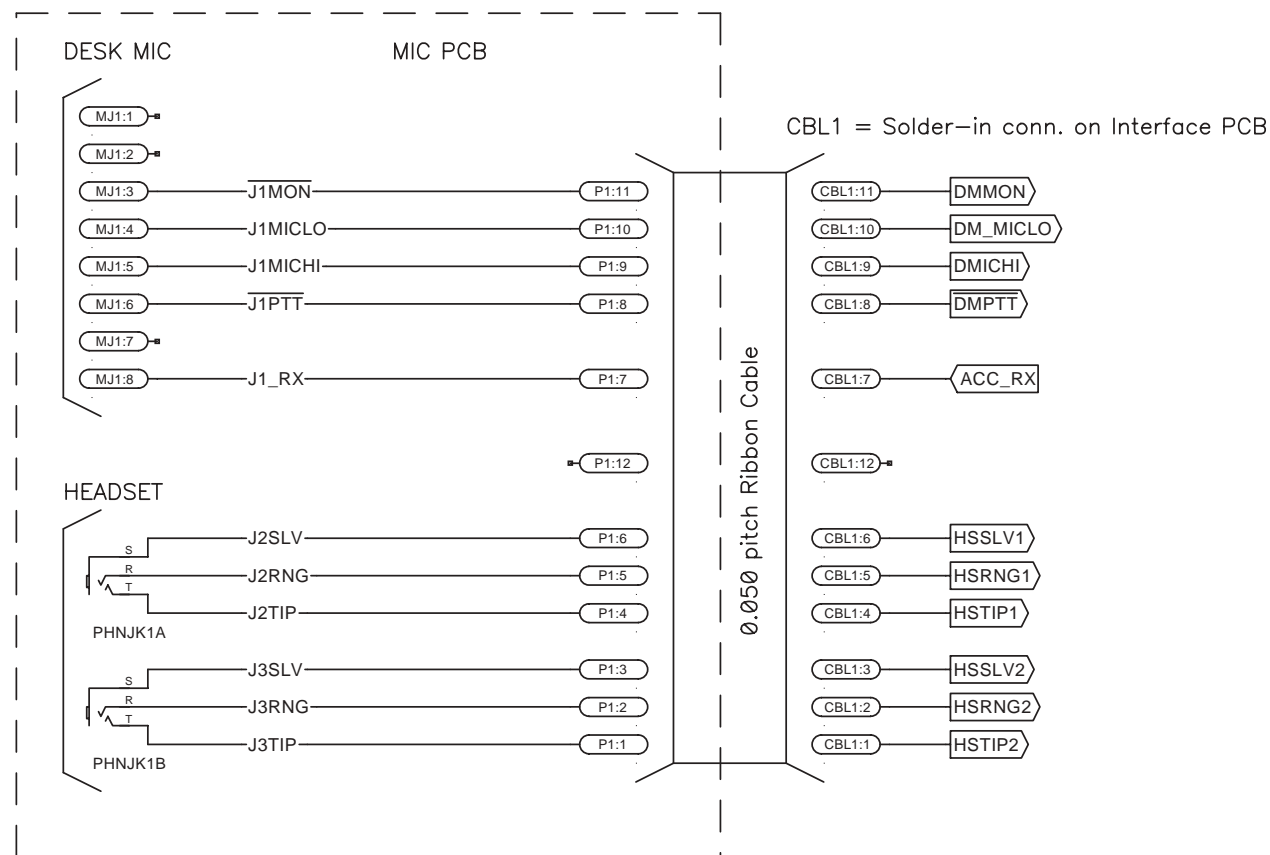
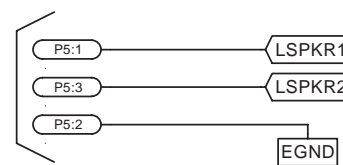

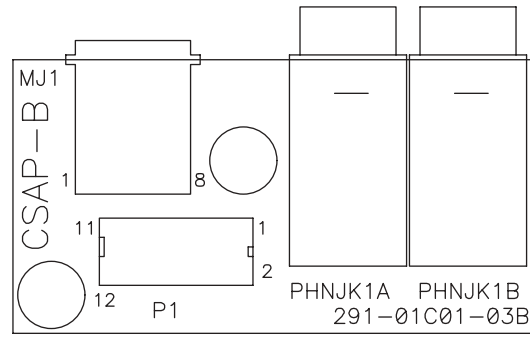

**CDM Control Station Audio Panel (CSAP)**



**CDM Control Station Key Panel (CSKP)**

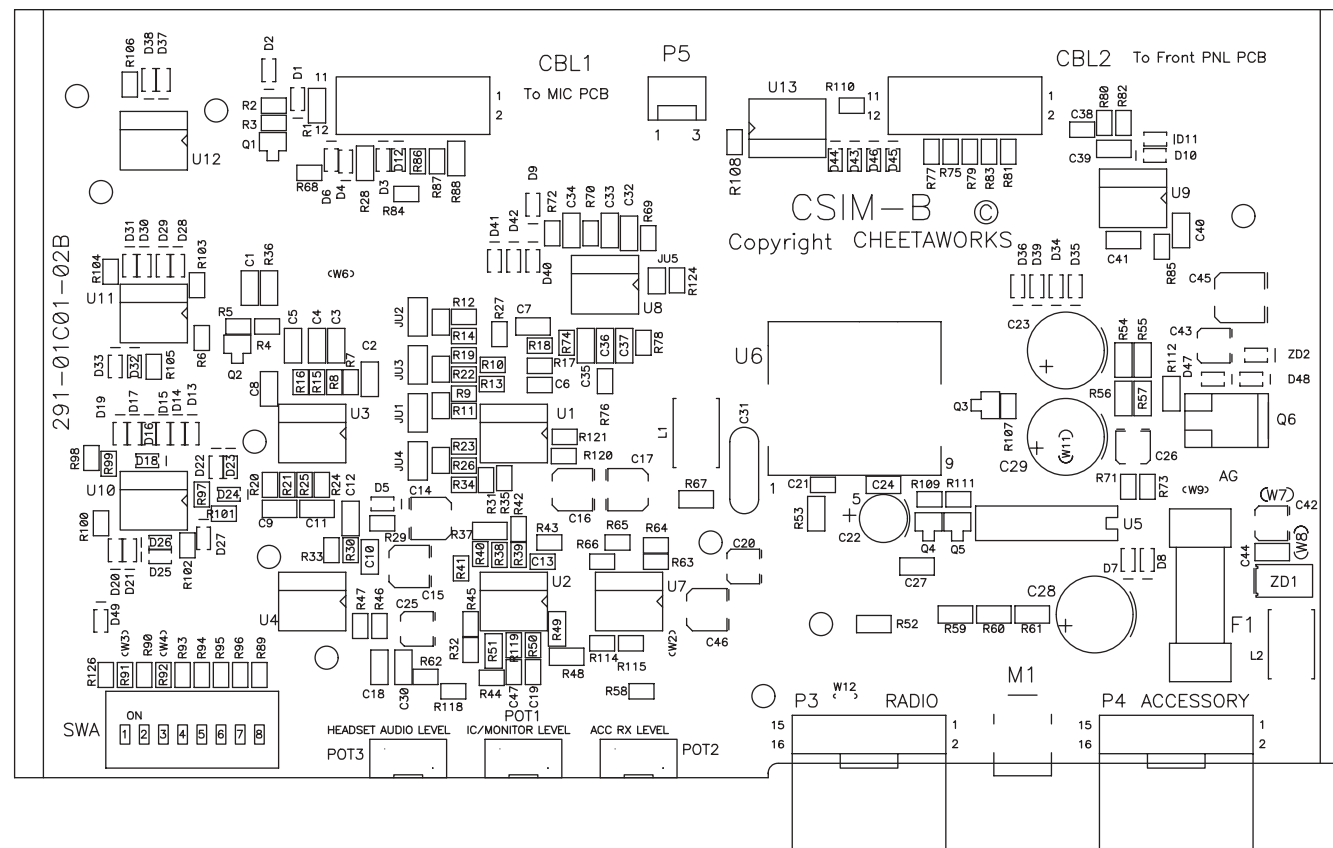

**CDM Control Station Interface Module (CSIM)**

# NOVA COMMUNICATIONS



**MOTOROLA**

*Authorized Dealer & Service Center*



**MOTOSTAR**

*1800 Customer Award*



**MOTOROLA**

*Authorized Channel Partner  
Fixed Wireless Broadband Solutions*

## Nova Communications

Canada's Premier Supplier  
of Wireless Communications  
We Put Wireless to Work!  
1-877-721-7070

[www.novacomunications.com](http://www.novacomunications.com)



Motorola, Inc.  
8000 West Sunrise Boulevard  
Ft. Lauderdale, FL 33322

MOTOROLA, and the Stylized M Logo, are registered  
in the U.S. Patent and Trademark Office. All other product  
or service names are the property of their respective owners.  
© Motorola, Inc. 2004.  
All rights reserved. Printed in U.S.A.



**6880309N15-A**